

# ITB – Throttle with Integrated Stepper Motor

P/N 30.43. xxx

Assembly Instructions



P/N 01.50.034 | Rev. 06/2022

Original assembly instructions

© Copyright 2022 MOTORTECH GmbH. All rights reserved.

MOTORTECH products and the MOTORTECH logo are registered and/or common law trademarks of the MOTORTECH GmbH. All further trademarks and logos displayed or used in this publication are the property of the respective entitled person and are used for reference purposes only.

Information contained in this publication may be changed without prior notice.

# Table of Contents



<b>1 General Information</b>	<b>4</b>
1.1 What Is the Purpose of these Assembly Instructions?	4
1.2 Who Are these Assembly Instructions Targeted to?	4
1.3 What Symbols Are Used in the Assembly Instructions?	4
1.4 Which Abbreviations/Acronyms Are Used in the Operating Manual?	5
<b>2 Safety Instructions</b>	<b>6</b>
2.1 Proper Disposal	6
<b>3 Intended Use</b>	<b>7</b>
3.1 Functional Description	7
3.2 Applications	8
<b>4 Product Description</b>	<b>9</b>
4.1 Technical Data	9
4.2 Warning Notices on the Device	10
4.3 Product Identification – Labeling on the Device	11
4.4 Digression: Control of the Stepper Motor	12
4.5 Overview Drawings	12
4.5.1 50 Series	13
4.5.2 100 Series	15
4.5.3 140 Series	17
4.5.4 150 Series	19
4.5.5 200 Series	21
<b>5 Wiring of the Device</b>	<b>23</b>
5.1 Connector Stepper Motor / Encoder	23
<b>6 Assembly Instructions</b>	<b>24</b>
6.1 Unpacking	24
6.2 Mounting the Device	24
6.3 Connecting the Device	26
<b>7 Errors</b>	<b>27</b>
<b>8 Maintenance</b>	<b>28</b>
8.1 Customer Service Information	28
8.2 Returning Equipment for Repair / Inspection	28
8.3 Instructions for Packaging the Equipment	28
8.4 Spare Parts and Accessories	28

# 1 General Information

Prior to use, read these assembly instructions carefully and familiarize yourself with the product. Installation and start-up should not be carried out before reading and understanding this document. Keep these assembly instructions readily available so that you can reference them as needed.

## 1.1 What Is the Purpose of these Assembly Instructions?

This installation instruction serves as an aid for the installation of the product and supports the technical staff with all maintenance tasks to be performed. Furthermore, this instruction is aimed at preventing dangers to life and health of the user and third parties.

## 1.2 Who Are these Assembly Instructions Targeted to?

This assembly instructions provide a code of conduct for personnel tasked with the setup, operation, maintenance, and repair of stationary engines. A certain level of technical knowledge with respect to the operation of stationary engines and basic knowledge of the electronic components used are necessary. Persons who are only authorized to operate the stationary engine shall be trained by the operating company and shall be expressly instructed concerning potential hazards.

## 1.3 What Symbols Are Used in the Assembly Instructions?

The following symbols are used in these instructions and must be observed:



### Example

This symbol indicates examples, which point out necessary handling steps and techniques. In addition, you receive additional information from the examples, which will increase your knowledge.



### Notice

This symbol indicates important notices for the user. Follow these. In addition, this symbol is used for overviews that give you a summary of the necessary work steps.



### Warning

This symbol indicates warnings for possible risks of property damage or risks to health. Read these warning notices carefully and take the mentioned precautionary measures.



## Danger

This symbol indicates warnings for danger to life, especially due to high voltage. Read these warning notices carefully and take the mentioned precautionary measures.

## 1.4 Which Abbreviations/Acronyms Are Used in the Operating Manual?

The following abbreviations/acronyms are used in the assembly instructions.

Abb.	Term	Description	Explanation
CPR	Counts Per Revolution	Counter results per revolution	Unit for the resolution of encoders
HT	High temperature		Device version designed for higher temperatures of the media flowing through.
ITB	Integrated Throttle Body	Throttle with integrated stepper motor	
MICT	MOTORTECH Integrated Configuration Tool		Configuration software for MOTORTECH control units
USB	Universal Serial Bus		Serial connection system to link a computer to external devices

## 2 Safety Instructions

The device is operated on a stationary engine. Please follow therefore all safety instructions of the equipment manufacturers, especially with regards to sections under high voltage. All work must be performed by trained and authorized personnel only.



### **Risk of injury!**

Turn off the engine prior to assembly and secure it from re-starting in order to avoid damage or injury.



### **Risk of injury and destruction**

The engine must be equipped with an independent emergency shutdown switch to avoid overspeed, which can cause destruction and/or injury.



### **Risk of burning!**

The surfaces of the system may heat up to high temperatures.

### **2.1 Proper Disposal**

For the proper disposal of MOTORTECH devices, observe the information provided at [www.motortech.de](http://www.motortech.de).

## 3 Intended Use

### 3.1 Functional Description

The ITB throttle controls the supply of the gas-/air mixture to the gas engine. The integrated stepper motor evaluates signals from a VariStep3 stepper motor driver and implements them in changing the opening of the throttle. The speed and power of the engine are regulated in this way.

#### System Overview (Example)

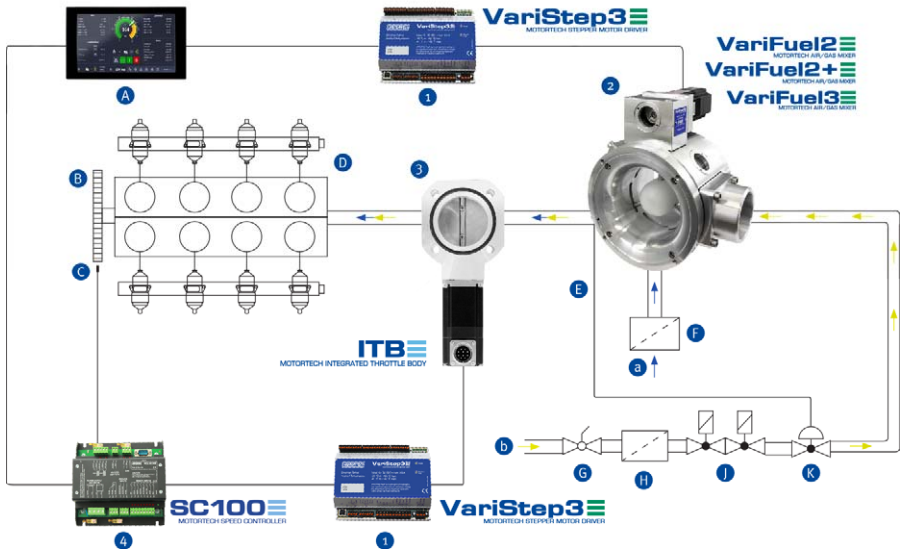

- |  |                                   |
|--|-----------------------------------|
| ① VariStep3 stepper motor driver             | Ⓐ Master control                  |
| ② VariFuel gas mixer                         | Ⓑ Flywheel                        |
| ③ ITB throttle with integrated stepper motor | Ⓒ Magnetic pickup                 |
| ④ SC100 speed controller                     | Ⓓ Engine                          |
| Ⓐ Air  | Ⓔ Impulse line                    |
| Ⓑ Gas  | Ⓕ Air filter                      |
|  | Ⓖ Ball valve                      |
|  | Ⓗ Gas filter                      |
|  | Ⓙ Double safety valve             |
|  | Ⓚ Balance/Zero pressure regulator |

## ■ 3 Intended Use

### 3.2 Applications

The ITB throttles are suitable for use on stationary gas engines. Series with different valve diameters are available for different gases and performance classes. A high temperature version (HT) can be used for operation in front of the intercooler. These permit a temperature of the medium flowing through of up to +200 °C (+392 °F).

Any use other than the one described in the assembly instructions shall be considered improper use and will result in the voiding of all warranties.



## 4 Product Description



### 4.1 Technical Data

The throttles have the following technical properties:

Feature	Value
Dimensions	See chapter <i>Overview Drawings</i> on page 12
Weight	See following table.
Shape of device	See chapter <i>Overview Drawings</i> on page 12
Maximum rotation angle of the throttle body	80°
Chemical resistance	Water, oil, gaseous fuels
Absolute pressure	4.5 bar (65 psi)
Maximum temperature of media flowing through	+125 °C (+257 °F) (standard version) +200 °C (+392 °F) (HT version)
Connection stepper motor	10-pole military style connector
Climatic environmental conditions	-20 °C to +85 °C (-4 °F to +185 °F) max. 95% humidity without condensation

### Weight

The weight depends on the type, series and diameter of the throttle.

Series	Diameter of the throttle body	Type	Weight
<b>50 series</b>	42 mm (1.65")	Standard	2.1 kg (4.63 lbs)
	42 mm (1.65")	HT	2.2 kg (4.85 lbs)
<b>100 series</b>	60 mm (2.36")	Standard	2.5 kg (5.51 lbs)
	60 mm (2.36")	HT	2.6 kg (5.73 lbs)
	68 mm (2.68")	Standard	2.6 kg (5.73 lbs)
	68 mm (2.68")	HT	2.7 kg (5.95 lbs)
<b>140 series</b>	75 mm (2.95")	Standard	3.8 kg (8.38 lbs)
	75 mm (2.95")	HT	3.9 kg (8.60 lbs)
	80 mm (3.15")	Standard	3.7 kg (8.16 lbs)
	80 mm (3.15")	HT	3.8 kg (8.38 lbs)
	85 mm (3.35")	Standard	3.6 kg (7.94 lbs)
	85 mm (3.35")	HT	3.7 kg (8.16 lbs)

## 4 Product Description

Series	Diameter of the throttle body	Type	Weight
<b>150 series</b>	90 mm (3.54")	Standard	7.0 kg (15.43 lbs)
	90 mm (3.54")	HT	7.2 kg (15.87 lbs)
	100 mm (3.94")	Standard	6.8 kg (14.99 lbs)
	100 mm (3.94")	HT	6.9 kg (15.21 lbs)
<b>200 series</b>	100 mm (3.94")	Standard	8.4 kg (18.52 lbs)
	100 mm (3.94")	HT	8.5 kg (18.74 lbs)
	105 mm (4.13")	Standard	8.1 kg (17.86 lbs)
	105 mm (4.13")	HT	8.2 kg (18.10 lbs)
	110 mm (4.33")	Standard	7.8 kg (17.20 lbs)
	110 mm (4.33")	HT	7.9 kg (17.42 lbs)
	115 mm (4.53")	Standard	7.5 kg (16.53 lbs)
	115 mm (4.53")	HT	7.6 kg (16.76 lbs)
	120 mm (4.72")	Standard	7.2 kg (15.87 lbs)
	120 mm (4.72")	HT	7.3 kg (16.09 lbs)
	125 mm (4.92")	Standard	6.9 kg (15.21 lbs)
	125 mm (4.92")	HT	7.0 kg (15.43 lbs)

### 4.2 Warning Notices on the Device

The following labels are located on the stepper motor:

English warning notice	German translation
CAUTION! Stepper motor rev. B only for use with VariStep stepper motor drivers. Do not use stepper motor to lift or carry the device.	VORSICHT! Schrittmotor Rev. B nur mit VariStep-Schrittmotorsteuerungen verwenden. Den Schrittmotor nicht zum Tragen oder Heben des Gerätes benutzen.

### Warning Symbol on Stepper Motor



Warning of hot surface

## 4 Product Description



### 4.3 Product Identification – Labeling on the Device

The necessary numbers for unique product identification are on the device:

#### Nameplate ITB on the Throttle Body



Abb.	Meaning
P/N	ITB part number
S/N	ITB serial number

#### Stepper Motor Nameplate



Abb.	Meaning
P/N	Part number of the stepper motor
PC	Production code
REV.	Revision of the stepper motor

## 4 Product Description

### 4.4 Digression: Control of the Stepper Motor

In the standard application, the stepper motor of the throttle is driven by the VariStep stepper motor driver. For example, if you want to implement a direct activation from a master control, you receive the technical details for activation of the stepper motor in the following section.

#### Technical Data of Stepper Motors

Feature	50, 100, 140 series	150, 200 series
Design	2-phase, bipolar	2-phase, bipolar
Maximum phase current	2.8 A	6.3 A
Recommended current	2 A (full step operation mode) 2.8 A (microstep operation mode)	2.8 A (full step operation mode) 4 A (microstep operation mode)
Step width	0.9°	1.8°
Recommended control	1/16 microstep operation mode	1/16 microstep operation mode

#### Technical Data of the Encoder

Feature	Values for all series
Operating voltage	5 V
Type	Incremental, quadrature signal
Signal form	A, B, index; TTL-compatible
Resolution	4,096 CPR
Index position	Throttle is completely closed

You can find the assignment of the connectors on the stepper motor and encoder in the section *Connector Stepper Motor/Encoder* on page 23.

### 4.5 Overview Drawings



#### Take military style connector into account

During planning of the installation, consider the dimensions of the military style connector on the harness (about 75 mm (2.95") on the 90° connector).

## 4 Product Description

### 4.5.1 50 Series

Standard diameter of the throttle (D): 42 mm (1.65")

possible diameters of the throttle: 41 mm (1.61") to 44 mm (1.73")

P/N 30.43.055-D and P/N 30.43.055-D-HT also correspond to the following drawings, but without the gasket (O-ring, 56.75 mm x 3.53 mm [2.23" x 0.14"]) and the groove required for it.

#### Standard version (P/N 30.43.050-D)

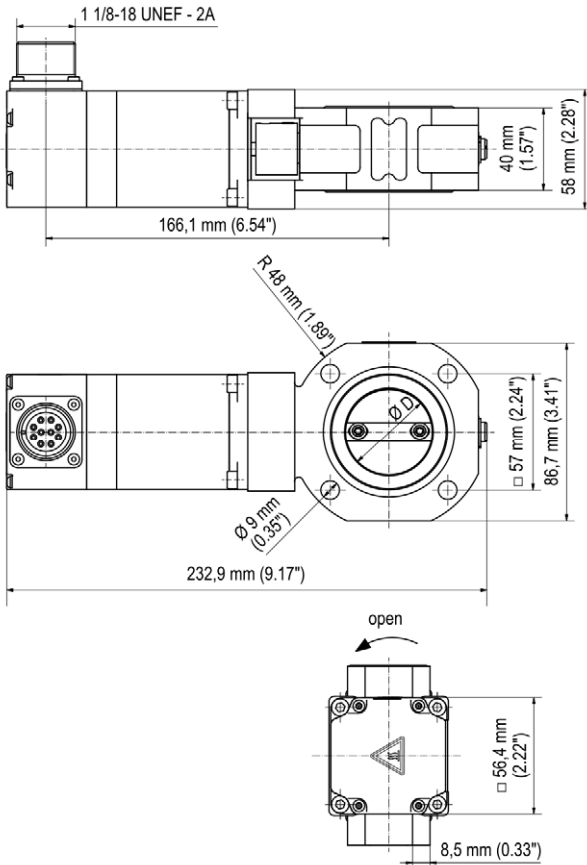

## 4 Product Description

### HT versions (P/N 30.43.050-D- HT)

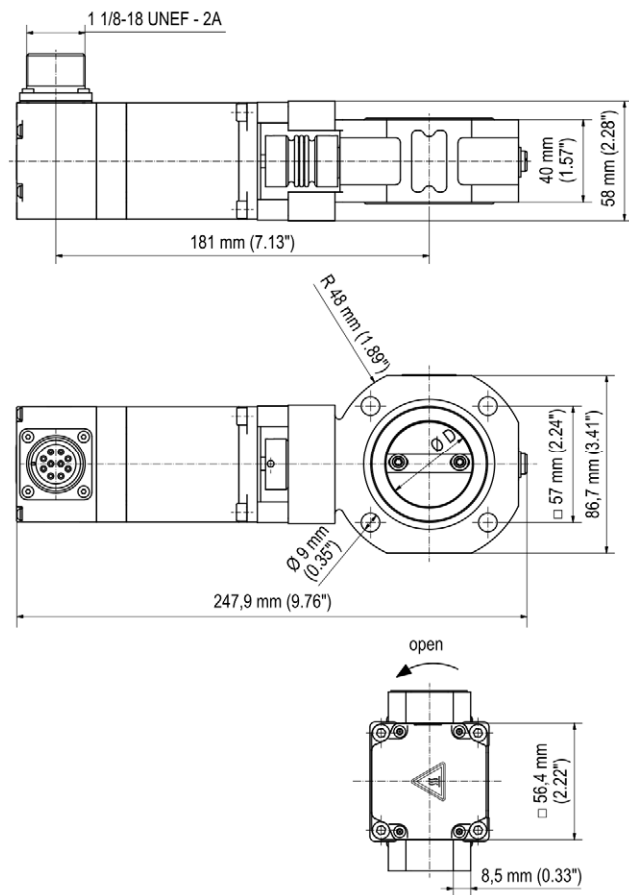

## 4 Product Description

### 4.5.2 100 Series

Standard diameters of the throttle (D): 60 mm (2.36"), 68 mm (2.68")  
possible diameters of the throttle: 48 mm (1.89") to 68 mm (2.68")

P/N 30.43.105-D and P/N 30.43.105-D-HT also correspond to the following drawings, but without the gasket (O-ring, 82.14 mm x 3.53 mm [3.23"x 0.14"]) and the groove required for it.

#### Standard version

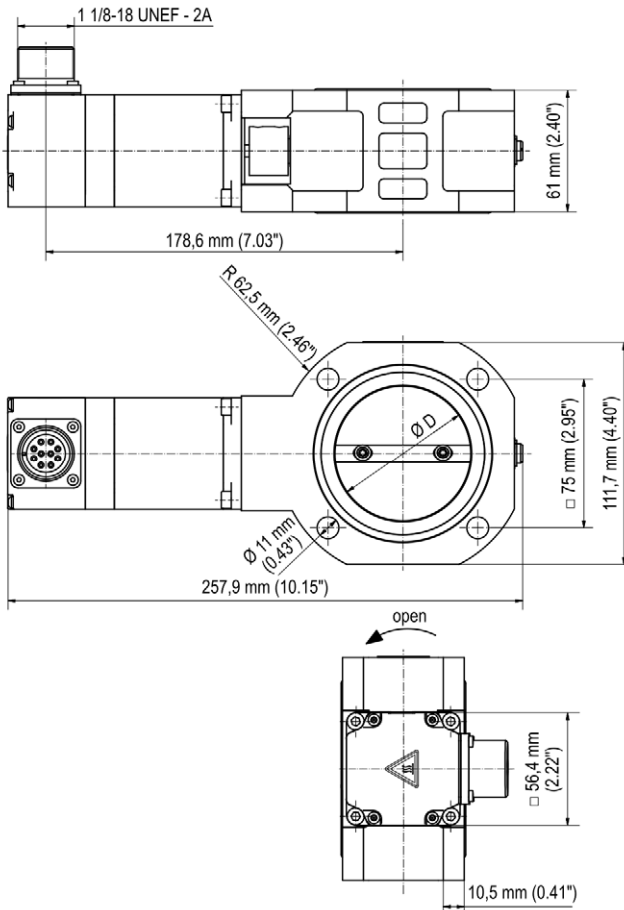

## 4 Product Description

### HT version

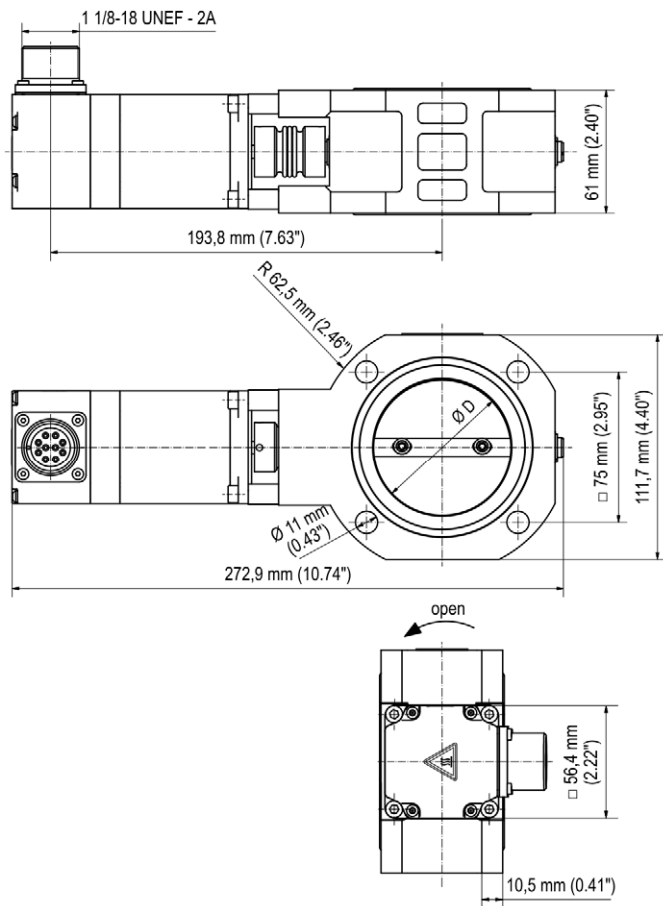



## 4 Product Description

### 4.5.3 140 Series

Standard diameters of the throttle (D): 75 mm (2.95"), 80 mm (3.15"), 85 mm (3.35")  
possible diameters of the throttle: 73 mm (2.8) to 85 mm (3.35")

P/N 30.43.145-D and P/N 30.43.145-D-HT also correspond to the following drawings, but without the gasket (O-ring, 98.02 mm x 3.53 mm [3.86"x 0.14"]) and the groove required for it.

#### Standard version

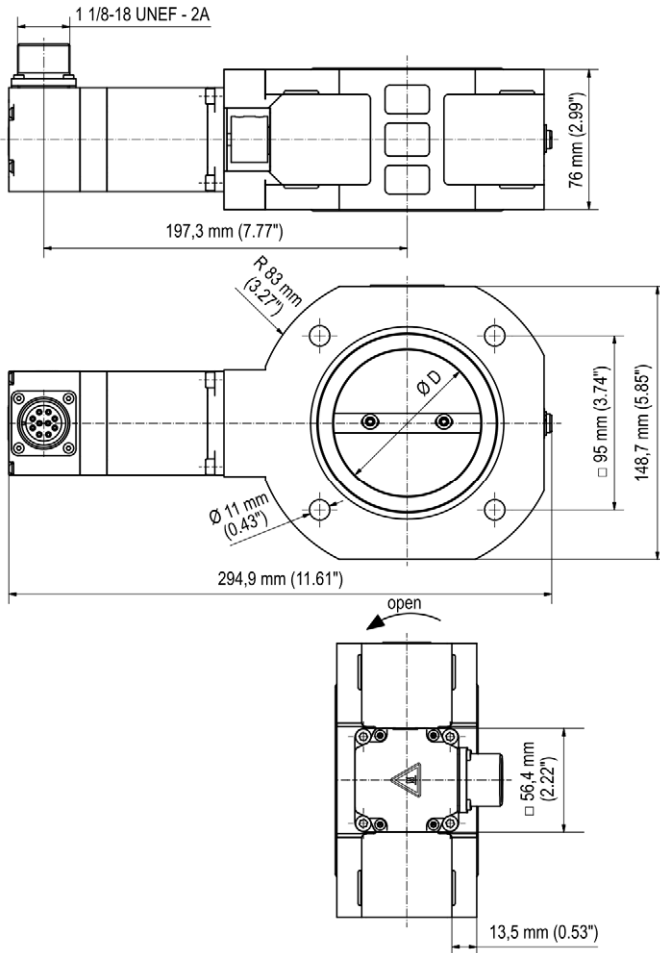

## 4 Product Description

### HT version

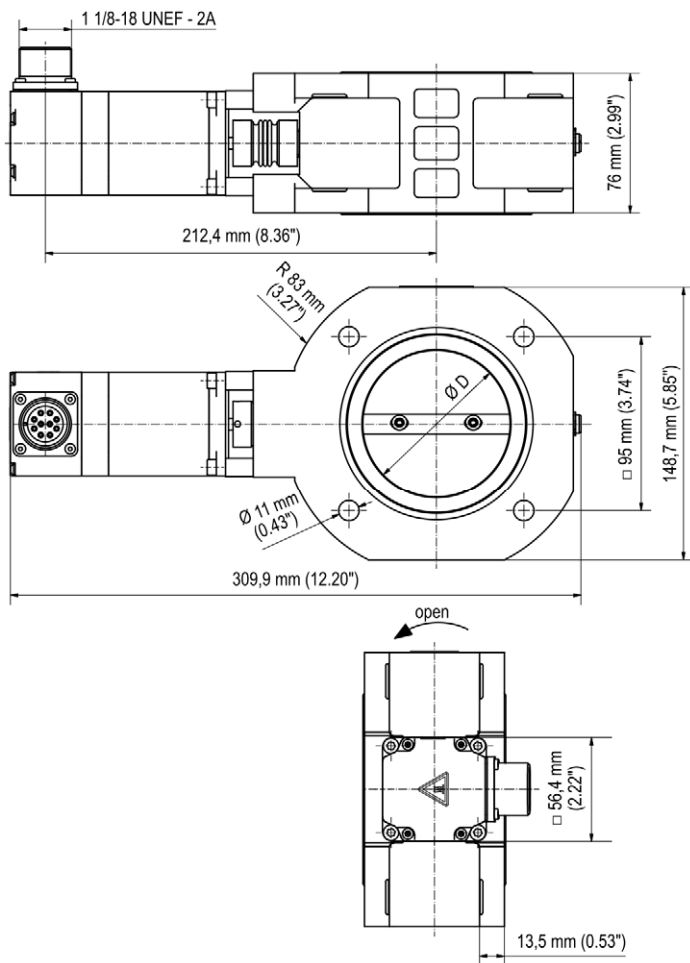

## 4 Product Description



### 4.5.4 150 Series

Standard diameters of the throttle (D): 90 mm (3.54"), 100 mm (3.94")

possible diameters of the throttle: 82 mm (3.23") to 104 mm (4.09")

P/N 30.43.155-D and P/N 30.43.155-D-HT also correspond to the following drawings, but without the gasket (O-ring, 116 mm x 3 mm [4.57"x 0.12"]) and the groove required for it.

#### Standard version

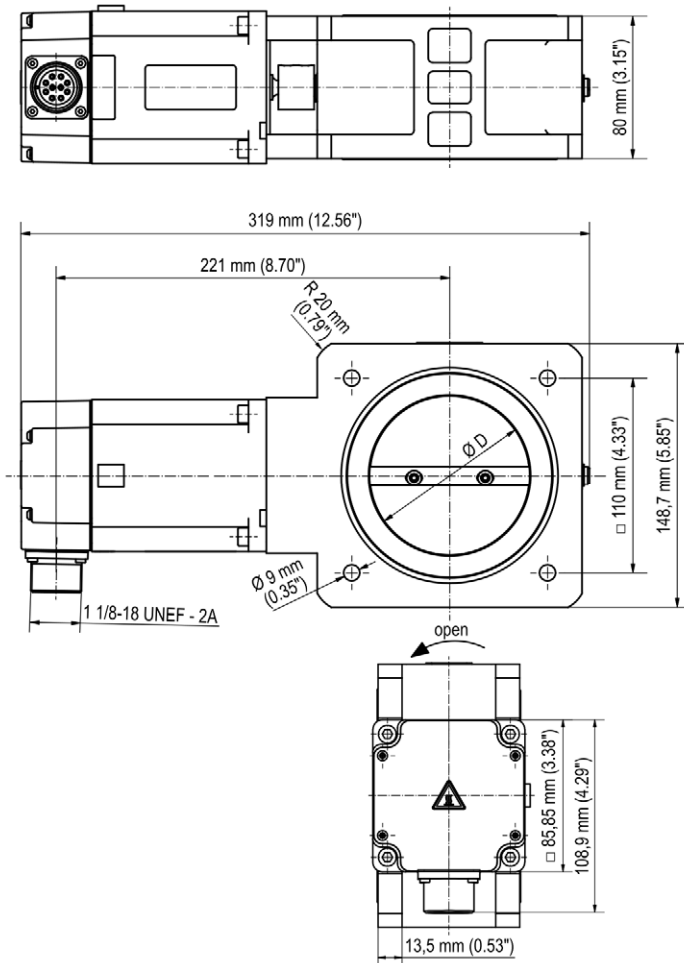

## 4 Product Description

### HT version

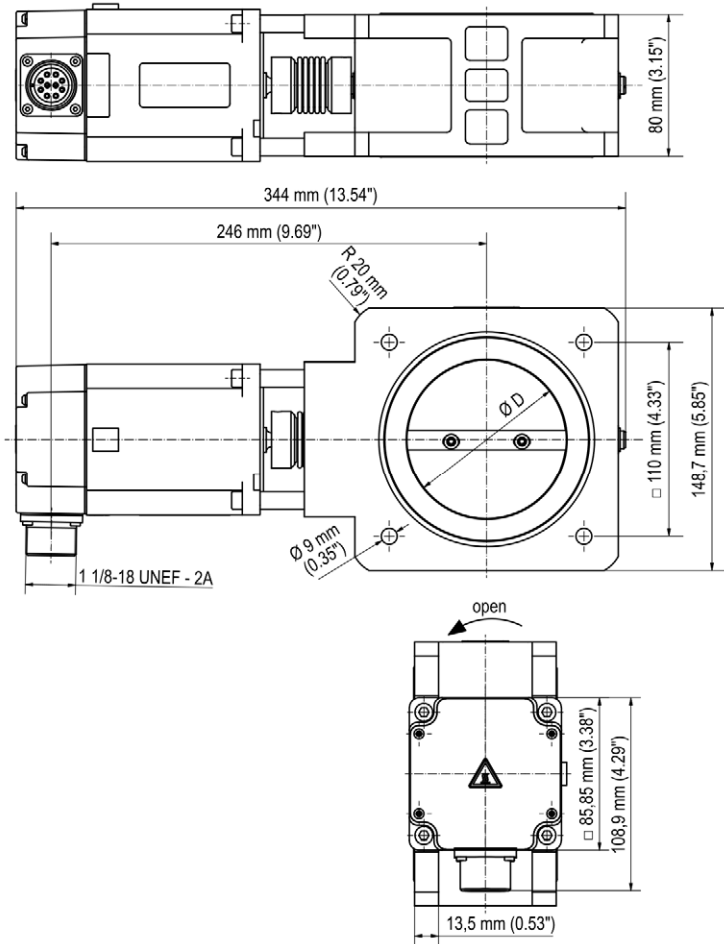

## 4 Product Description



### 4.5.5 200 Series

Standard diameters of the throttle (D): 100 mm (3.94"), 105 mm (4.13"), 110 mm (4.33"), 115 mm (4.53"), 120 mm (4.72"), 125 mm (4.92")

possible diameters of the throttle: 98 mm (3.86") to 125 mm (4.92")

P/N 30.43.205-D and P/N 30.43.205-D-HT also correspond to the following drawings, but without the gasket (O-ring, 148.82 mm x 3.53 mm [5.86" x 0.14"]) and the groove required for it.

#### Standard version (P/N 30.43.200-D)

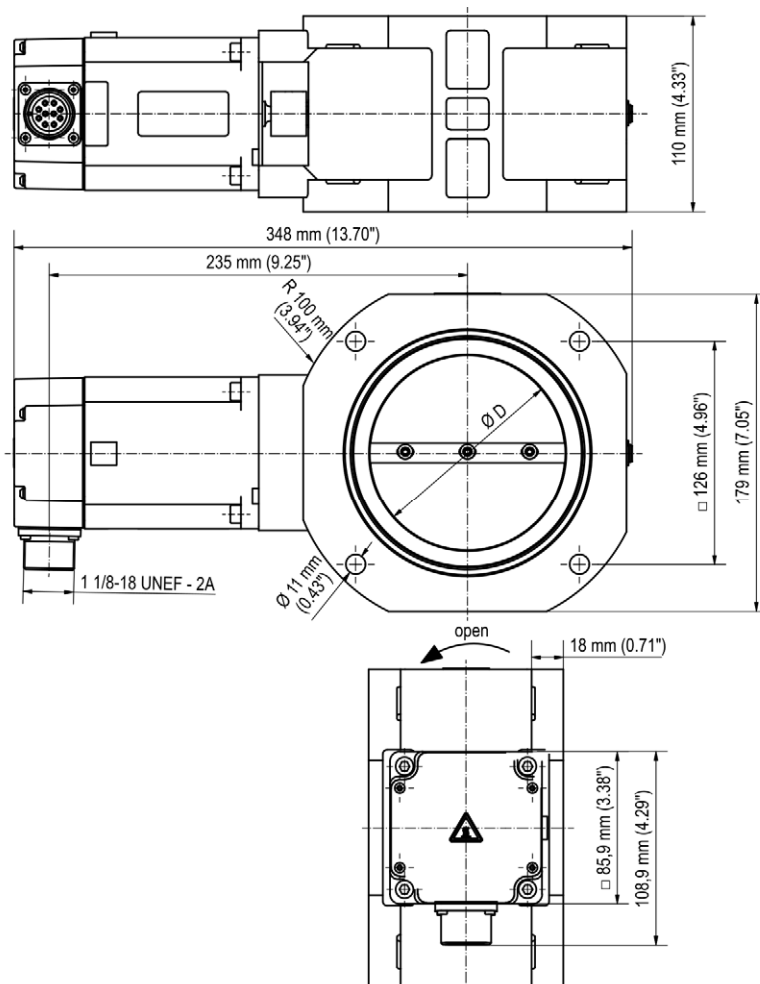

## 4 Product Description

HT versions (P/N 30.43.200-D- HT)

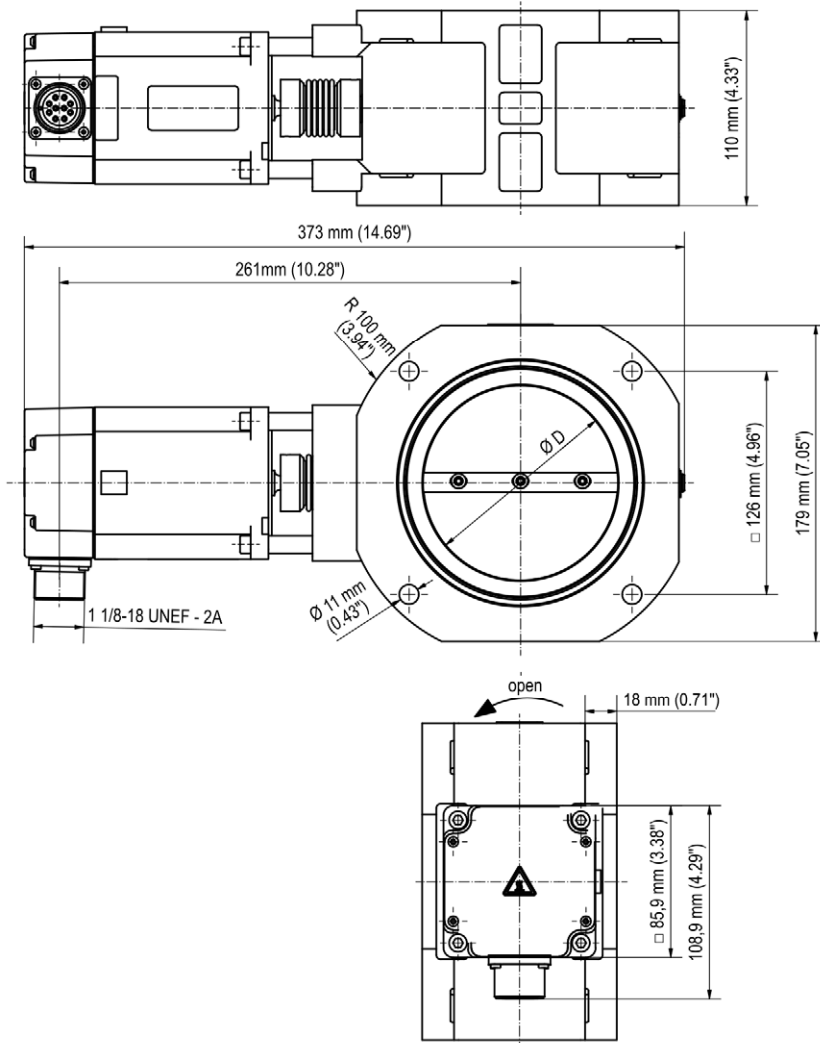

## 5 Wiring of the Device

### 5.1 Connector Stepper Motor / Encoder

The connection of the stepper motor to the VariStep stepper motor driver is carried out using the original MOTORTECH harness via the 10-pin connector on the stepper motor:

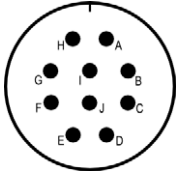

Pin	Description
A	Stepper motor phase A1
B	Stepper motor phase A2
C	Stepper motor phase B1
D	Stepper motor phase B2
E	Encoder A
F	Encoder B
G	Encoder I (index)
H	Encoder shield
I	Encoder 5V supply voltage
J	Encoder GND (ground)

## 6 Assembly Instructions

### 6.1 Unpacking

Unpack the device taking care not to damage it, and ensure that the assembly instructions are always stored with the device and are easily accessible. Check the contents for completeness and verify that the device type meets your application requirements.

#### Scope of Supply

The scope of supply of the device consists of the following components:

- Throttle including stepper motor
- Two O-rings, if necessary
- Assembly instructions

#### Required Accessories

- Connection cable for connection between the throttle and stepper motor driver
- VariStep stepper motor driver incl. configuration software MICT and USB interface cable

### 6.2 Mounting the Device



#### ITB types without groove

ITB types without groove can be used if the mounting flanges have a gasket. Alternatively, a suitable gasket must be inserted between the ITB and the connecting flange.

The installation location of the throttle body can be freely selected.

1. Insert the supplied O-rings into the corresponding groove on both sides of the throttle body (see figure).



## 6 Assembly Instructions

Example: 140 series

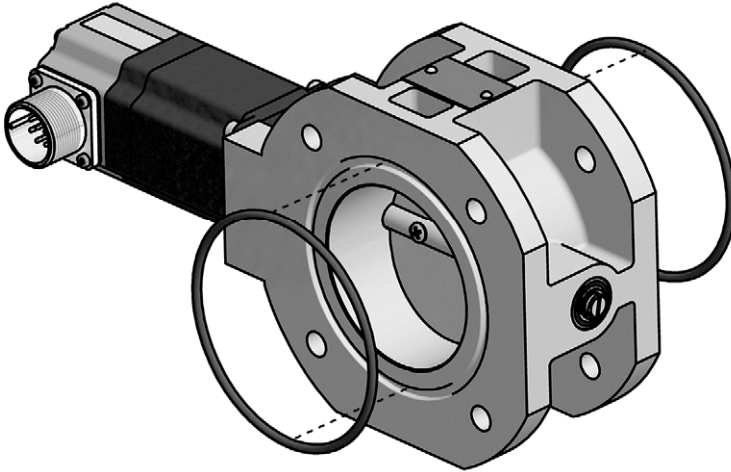

2. Use four through bolts or threaded rods (strength class 8.8 or higher) to mount the butterfly valve between the two flanges.

Depending on the thread used, observe the following tightening torques (for strength class 8.8):

- M8: 25 Nm  $\pm$  10% (18.4 lb-ft  $\pm$  10%)
- M10: 49 Nm  $\pm$  10% (36.1 lb-ft  $\pm$  10%)

## 6 Assembly Instructions

### 6.3 Connecting the Device



#### Risk of destruction!

Please observe the following procedure when connecting the stepper motor to the VariStep stepper motor driver:

1. Configure the VariStep stepper motor driver for the desired ITB throttle (see section *External device* in the operating manual for the VariStep stepper motor driver).
2. Disconnect the stepper motor driver from the power supply.
3. Connect the stepper motor of the throttle to the stepper motor driver.
4. Connect the VariStep stepper motor driver again to the power supply.
  - ▶ Now, the stepper motor driver will initiate a reference run. The throttle is ready for operation.



#### Follow operating manuals

Follow the operating manual during connection and start-up for the VariStep stepper motor driver and for the connected speed control.

1. Connect the harness with the military style connector to the stepper motor of the ITB throttle.
2. Connect the open end of the harness with the connector for stepper motor and encoder to the stepper motor driver. For this, read the operating manual for the VariStep stepper motor driver.
3. Connect the speed control to the VariStep stepper motor driver.
4. Connect the VariStep stepper motor driver to the power supply.
  - ▶ Now, the stepper motor driver will initiate a reference run. If the stepper motor driver is in automatic mode, the signals of the connected speed controller are then carried out. If the stepper motor driver is in manual mode, the throttle stays in the closed position.



### Observe error messages in MICT

If malfunctions occur, observe in general the error messages in MICT. These can help you to narrow down the errors. For this, also read the corresponding sections in the operating manual on the VariStep stepper motor driver.

#### Problem:

Throttle does not move although corresponding signals are sent from the stepper motor driver. You can recognize this problem by the fact that the groove on the axis of the throttle does not move in the event of corresponding signals.

#### Possible Causes and Solutions:

##### Cause 1:

The wiring between the VariStep stepper motor driver and ITB throttle is defective.

##### Solution 1:

Check the connection harness and the connections to the stepper motor driver. For this, also read the corresponding sections in the operating manual on the VariStep stepper motor driver.

##### Cause 2:

The VariStep stepper motor driver was incorrectly configured.

##### Solution 2:

Check the configuration via the MICT. Observe the error messages displayed. For this, also read the corresponding sections in the operating manual on the VariStep stepper motor driver.

##### Cause 3:

The stepper motor is defective.

##### Solution 3:

The ITB throttle has to be replaced. Please contact your MOTORTECH contact person.

## 8 Maintenance

### 8.1 Customer Service Information

You can reach our customer service during business hours at the following phone and fax number, or by email:

Phone: +49 5141 93 99 0  
Fax: +49 5141 93 99 99  
Email: [service@motortech.de](mailto:service@motortech.de)

### 8.2 Returning Equipment for Repair / Inspection

To return the device for repair and inspection, obtain a return form from your MOTORTECH contact person (see *Customer Service Information* on page 28).

After you have completely filled out the return form and returned it to MOTORTECH, MOTORTECH will send you back the return form and a delivery note with RMA number specified. Enclose the return form with your device and attach the delivery note to the packaging so that it is clearly visible from the outside. This will ensure a speedy and smooth processing of your repair order.

Send the device with delivery note and return form to one of the two addresses below or to the nearest MOTORTECH representative:

#### MOTORTECH GmbH

Hogrevestr. 21–23  
29223 Celle

Germany

Phone: +49 5141 93 99 0  
Fax: +49 5141 93 99 98

[www.motortech.de](http://www.motortech.de)  
[motortech@motortech.de](mailto:motortech@motortech.de)

#### MOTORTECH Americas, LLC

1400 Dealers Avenue, Suite A  
New Orleans, LA 70123

USA

Phone: +1 504 355 4212  
Fax: +1 504 355 4217

[www.motortechamericas.com](http://www.motortechamericas.com)  
[info@motortechamericas.com](mailto:info@motortechamericas.com)

### 8.3 Instructions for Packaging the Equipment

For return shipment, equipment should be packaged as follows:

- Use packaging material that does not damage the equipment surfaces.
- Wrap the equipment with sturdy materials and stabilize it inside the packaging.
- Use sturdy adhesive film to seal the packaging.

### 8.4 Spare Parts and Accessories

For spare parts and accessories, please refer to our current Product Guide, which is available for you to download on the internet at [www.motortech.de](http://www.motortech.de).



**MOTORTECH GmbH**

Hogrevestr. 21–23  
29223 Celle  
Germany

Phone: +49 (5141) 93 99 0  
Fax: +49 (5141) 93 99 99  
E-Mail: [sales@motortech.de](mailto:sales@motortech.de)  
Web: [www.motortech.de](http://www.motortech.de)

**MOTORTECH Americas, LLC**

1400 Dealers Avenue, Suite A  
New Orleans, LA 70123  
USA

Phone: +1 (504) 355 4212  
Fax: +1 (504) 355 4217  
E-Mail: [info@motortechamericas.com](mailto:info@motortechamericas.com)  
Web: [www.motortechamericas.com](http://www.motortechamericas.com)

**MOTORTECH Shanghai Co. Ltd.**

Room 1018 Enterprise Square,  
No. 228 Meiyuan Road,  
Jing'An District, 200070 Shanghai  
China

Phone: +86 (21) 6380 7338  
E-Mail: [info@motortechshanghai.com](mailto:info@motortechshanghai.com)  
Web: [www.motortechshanghai.com](http://www.motortechshanghai.com)

## GAS ENGINE TECHNOLOGY

Ignition Systems	Red
Spark Plugs & Accessories	Orange
Gas Engine Control Systems	Light Blue
Sensor Systems	Yellow
Air/Fuel Ration Control Systems	Green
Exhaust Gas Aftertreatment	Green
Gas Engine Accessories	Grey